

Products for High Voltage Application

AT35, AT38, AT41

Indoor current transformer for oil-immersed power transformers

Technical parameters	Value
Highest voltage for equipment	1.2 kV
Power frequency voltage, 1 min.	6 kV
Rated primary current	Up to 10 000 A (*)
Rated short-time thermal current	Up to 100 kA/1s
Rated dynamic current	Up to 120 kA

(*) Applicable for AT41 only. For AT35 and AT38 is rated primary current up to 5 000 A. Other parameters on request.

Description

AT transformers type have a frame construction and no primary winding. Under operating conditions, the bushing insulator, which is the main current transformer insulation, also serves as the primary winding. The secondary windings are evenly wound on the circumference of the toroidal core.

AT35 and AT41 are a metal design with aluminum flanges and stainless steel fasteners and second one AT38 is an oil-absorbing design with laminated pressboard HDLC and composite fasteners. There are placed a secondary coils between flanges. The flanges and fasteners provide mechanical support.

Operating temperature is up to 120°C. There are two subtypes and eleven different dimensions for metal design and eight different dimensions for oil-absorbing design. On both designs there is a major parameter outer diameter of flanges. Others as inner diameter and height are customized to depend on demand.

The secondary windings are designed for metering or protection purposes. Unused winding have to be earthed during the transformer operation (unused short-circuited also).

Compliance with standards

The transformers are designed and manufactured in conformity with the following standards:

- IEC 61869-1; 61869-2;
- IEC 60044-1;
- IEC 60044-6;
- ANSI/IEEE C57.13;
- GOST 7746-2001;
- Additional national standards and regulations on request.

The transformer can be installed by authorized person only and needs to comply with instructions for installation, use and maintenance.

Individual types

The individual types of the metal design transformers AT35 and AT41:

Type	Circle diameter of fixing holes [mm]	Fixing device	Max weight [kg]
AT35-300	269	M12	800
AT35-360	331		
AT35-400	370		
AT35-465	433		
AT35-500	470		
AT35-550	520		

Type	Circle diameter of fixing holes [mm]	Fixing device	Max weight [kg]
AT41-650	619	M16	1 200
AT41-750	720		
AT41-870	837		
AT41-970	940		
AT41-1055	1 025		

The individual types of the oil-absorbing design transformer AT38:

Type	Circle diameter of fixing holes [mm]	Fixing device	Max weight [kg]
AT38-310	270	M16 glass fiber stud	600
AT38-380	340		
AT38-410	370		
AT38-480	440		
AT38-510	470		
AT38-560	520		
AT38-660	620		
AT38-760	720		
AT38-880	840		

Termination of the secondary winding



Fig. 1. The cables terminated by an end sleeve (cable section 6 mm²)



Fig. 2. The cables terminated by a cable lug (cable section 35 mm²)

The cable termination with an end sleeve (Fig. 1.) is standardly used for a secondary outlets, whereas a cable lug (Fig. 2.) is standardly used for testing primary or screening electrodes. Other options are available on request.

CT type		AT35-xxx	AT41-xxx	AT38-xxx
Outer diameter/ height	[mm]	Up to 550/500	Up to 1055/500	Up to 880/500
Insulation level	kV		1.2/6/ -	
rated primary current	[A]	Up to 5 000	Up to 10 000	Up to 5 000
rated secondary current	[A]		1...5	
Number of secondary coils	-		6 max.	
Accuracy class			0.2-0.2S-0.5-0.5S-1-3-5-5P-10P-TPY 0.3-0.6-1.2-Cxxx	
Rated output	[VA]		200	
Accuracy limit factor/ factor security	-		ALF 5-50/FS 5-10	
lth rated short-time current	[kA/ 1s]		Up to 100	
ldyn dynamic withstand current	[kA]		Up to 120	
Frequency	[Hz]		50 or 60	
Rated continuous thermal current	[%]		Up to 200	
Weight	[kg]	Up to 800	Up to 1 200	Up to 600
Operating temperature	[°C]		Up to 120	
Installation (ambient conditions)	-		Fully immersed in transformer oil	
Number of output leads	-		30 max.	

NOTE: All specified technical data noted according available market request.

Marking of current transformer outlets

Secondary outlets are marked with label and different color. What color and label is assigned to each wire you can see in table below.

test wire (measure side)	black or white marked with M
test wire (earth side)	black or white marked with Ground
screen earth	black or white marked with Ground
secondary wire xS1(X1, Y1, Z1, U1, V1, W1)	black and marked with core/terminal no.
secondary wire xS2(X2, Y2, Z2, U2, V2, W2)	red and marked with core/terminal no.
secondary wire xS3(X3, Y3, Z3, U3, V3, W3)	yellow and marked with core/terminal no.
secondary wire xS4(X4, Y4, Z4, U4, V4, W4)	blue and marked with core/terminal no.
secondary wire xS5(X5, Y5, Z5, U5, V5, W5)	grey and marked with core/terminal no.
secondary wire xS6(X6, Y6, Z6, U6, V6, W6)	brown and marked with core/terminal no.



Fig. 3. An example of a secondary wire marking

NOTE: The transformer in the picture (Fig. 3.) is equipped with a reactor. The possibility of applying the reactor is individual and can be placed in inside or outside diameter in case of use.

Dimensional Drawings

AT35, AT38, AT41

AT35 and AT41

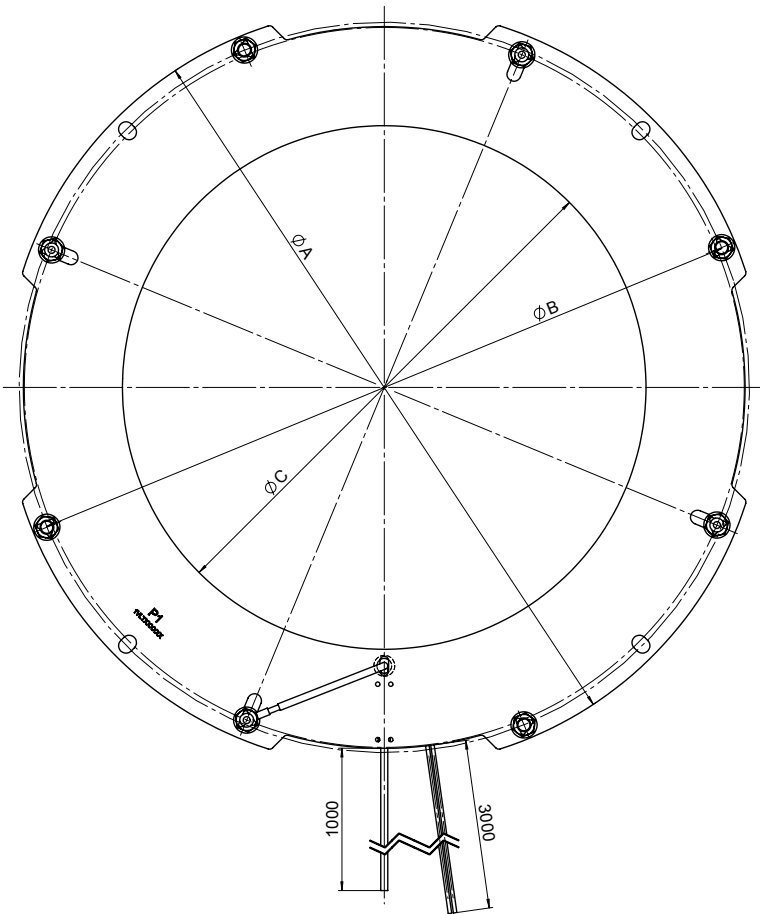
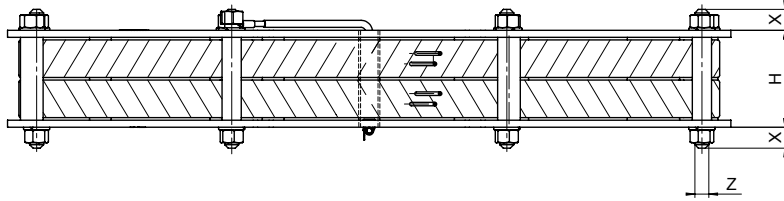

ZNAK / SIGN	HODNOTA / VALUE	
	AT35	AT41
A [mm]	300 - 550	650 - 1055
B [mm]	269 - 520	619 - 1025
C [mm]	ACC. REQUIREMENTS	
X [mm]	17	24
H [mm]	ACC. REQUIREMENTS	
Z	M12	M16

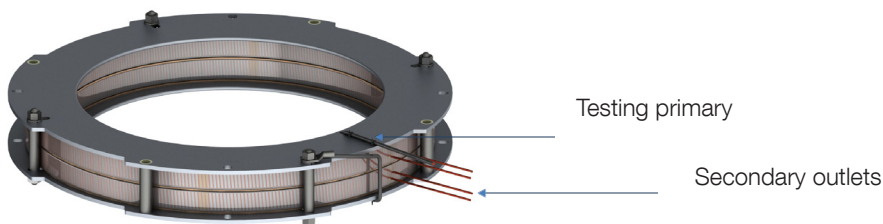

The Length of an outlets (testing primary, secondary outlets) is optional and depends on customer request. The fixing parts are a part of a delivery, mounting parts can be ordered separately as an attachment.

AT38

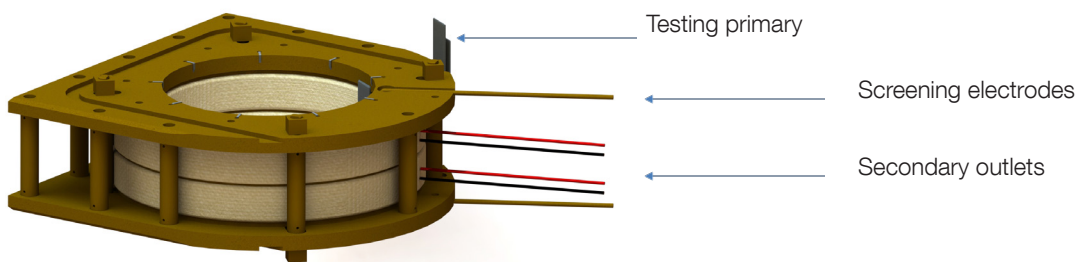
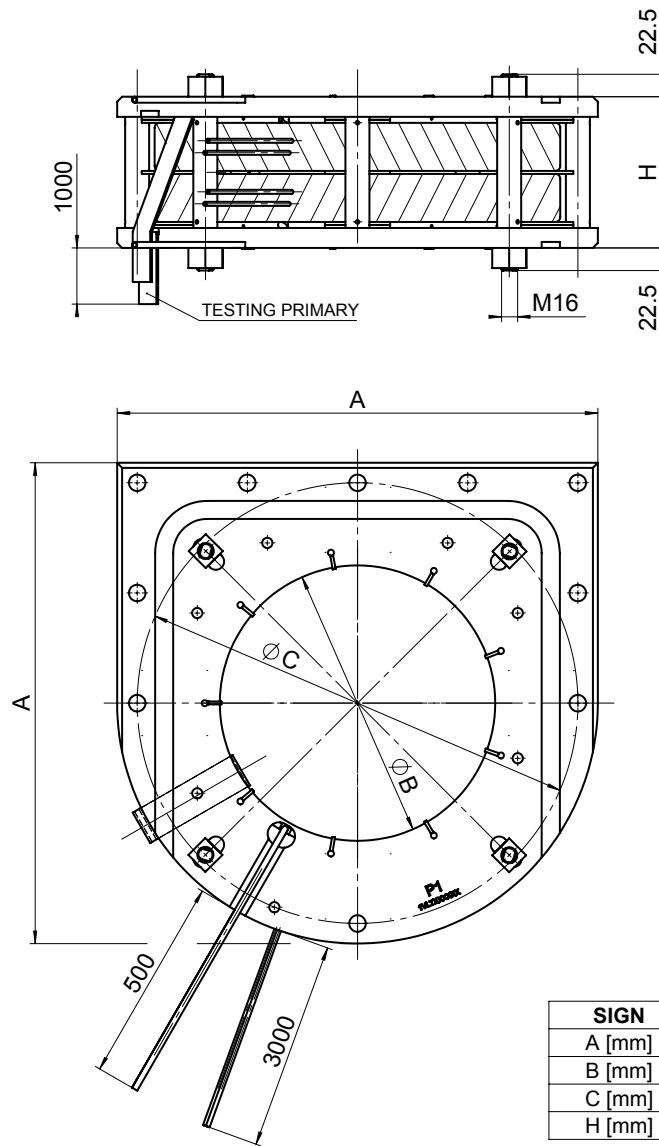

The Length of an outlets (testing primary, secondary outlets) is optional and depends on customer request. The fixing parts are a part of a delivery, mounting parts can be ordered separately as an attachment.

Contact us

ABB s.r.o.
EPMV Brno

Videnska 117, 619 00 Brno,
Czech Republic

Tel.: +420 547 152 021

+420 547 152 614

Fax: +420 547 152 626

E-mail: info.ejf@cz.abb.com

www.abb.com

The data and illustrations are not binding. We reserve the right to make changes without notice in the course of technical development of the product.

© Copyright 2016 ABB.
All rights reserved.